

CUSTOM SOLUTIONS

KELLER's modular product design offers great flexibility and allows customer-specific adaptations to be produced without spiralling costs – even for small quantities.



TECHNOLOGY & DEVELOPMENT

KELLER has half a century of experience thanks to many demanding projects in a wide range of industries.

«Thanks to our technological expertise, longstanding experience and mastery of the many processes involved in manufacturing pressure sensors, coupled with a high level of vertical integration, we can make even the impossible possible.»

Bernhard Vetterli, Technical Director

KELLER DIAMANT

A new main building is currently being built in Winterthur, into which the entire production will move in 2026. KELLER is committed to Switzerland as a location and will continue to focus on «Swiss Made» in the future.



+ KELLER

KELLER Pressure

Headquarters
St. Gallerstrasse 119
8404 Winterthur
Switzerland

Phone +41 52 235 25 25
info@keller-pressure.com
www.keller-pressure.com



+ KELLER

KELLER PRESSURE

THE ORIGINAL SINCE 1974





The KELLER seal symbolises KELLER quality, it contains the most important values of the company and tells its story.

PRESSURE SENSORS WITH MAXIMUM ACCURACY



With an accuracy class of 0.05 %FS, our KELLER pressure sensors make it into the most sensitive applications.

FAMILY BUSINESS



The KELLER seagull symbolises freedom and independence. These values are of paramount in this family-owned business and ones we live by. KELLER is proud to still be an independent company today.

KELLER IS THE ORIGINAL



The integrated silicon measuring cell is the centrepiece of all our KELLER products. It was invented by the company founder Hannes W. Keller – more than 50 years ago.

The proof:
United States Patent
US 4103273

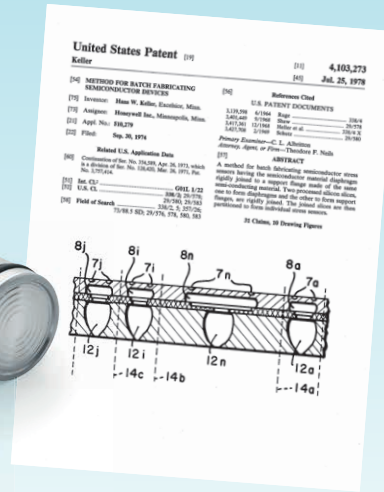

UNIQUE MEASURING AND TESTING EXPERTISE



The demands for quality in the market are very high. Thanks to our extensive measuring and testing expertise, we can increase these even further. Few can calibrate and test pressure sensors as accurately and in such quantities as KELLER.

Find out more about our measurement and testing expertise here:



SINCE 1974



Since its foundation, KELLER has produced the entire vertical range of products, from development to design, at its headquarters in Winterthur (Switzerland).



«SWISS MADE»



KELLER products are «Swiss Made» and, like the company, stand for expertise, quality, tradition and a down-to-earth attitude.

Find out more exciting details about the KELLER seal of quality here:

